

# Refined Biodiesel production...



*The revamped Fox Petroli biodiesel production plant.*

*The demand for Biodiesel is growing at a significant rate. The new generation oil industries are fast improving and more efficient thanks to cutting edge technology.*

**Fox Petroli Spa di Vasto (CH)** is a consolidated national reality born to satisfying a variety of needs deriving from the main energy factors of our economy. In addition to becoming a well known name in the marketing of oil byproducts (gasoline, fuel oil, lubricants), Fox Petroli Spa has lately been concentrating its efforts on developing new forms of fuel products focused on environmental protection. The latest important result is their production of biodiesel called BIOFOX, an ecological fuel obtained from rapeseed oil, purposely produced for reducing harmful emissions produced by motor engine fuel. Just one year ago the Fox Petroli's Vasta plant, Italian leaders in biodiesel productions, decided to optimize its production process by investing in revamping its plant technology with advanced automation and control lines. To achieve these goals they turned to **ESEA group**, who have twenty years experience in the world of factory automation, and **Progea** as the Solution Providers.

### The process

98% of biodiesel is made up of methyl esters from fatty acids. The process used to make refine raw rapeseed into a combustible chemical-physics like property similar to diesel oil is called 'transesterification'. Methanol and ethanol are also used in this various processes throughout the industry sector.

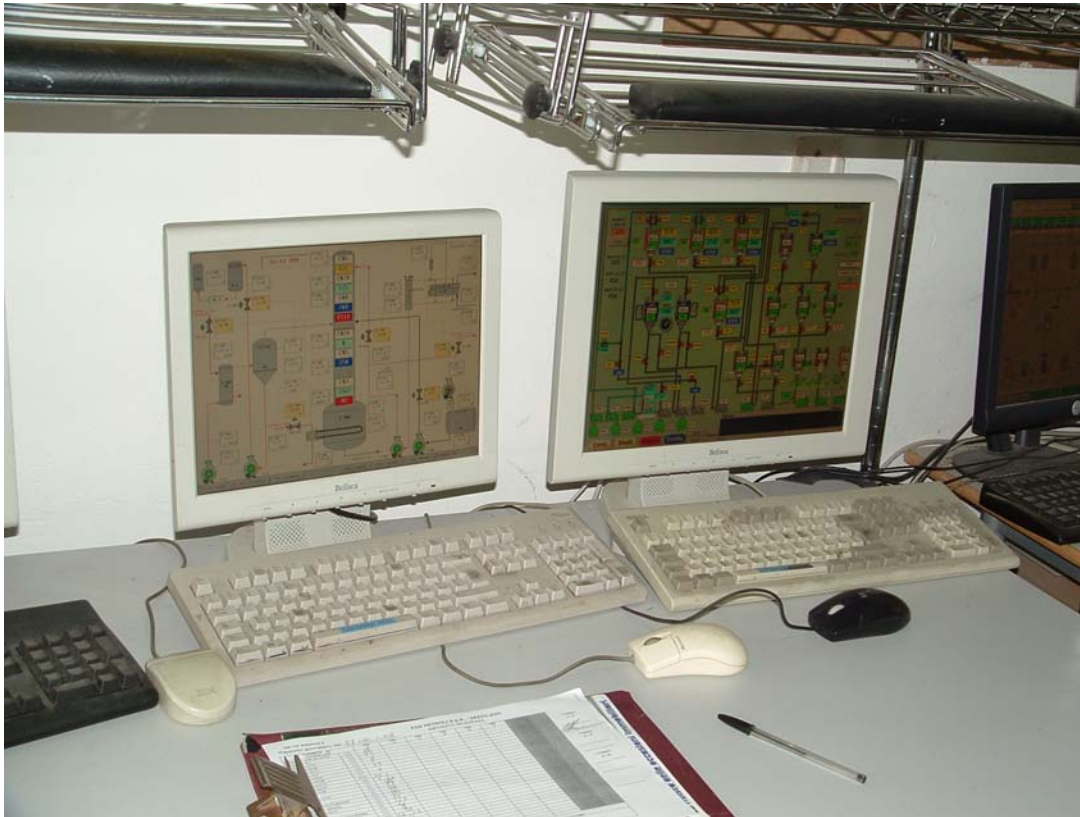

*The Biodiesel plant Control Room. The plant workers can control the whole process using the redundant Movicon supervision workstations.*

### The solution

Due to the super-criticality of the plant a reliable and expandable solution was needed that was easy to maintain, quick to development and integrate. FOX also specified for a redundant and mission critical architecture, to ensure service and data storage continuity at all times. ESEA chose Movicon the SCADA (supervisory, Control and Data Acquisition) platform software, as the solution to adopt, thought ideal for their client's demands and capable of guaranteeing maximum reliability united with great

flexibility and quick-to-develop at the same time.

To meet and satisfy the needs requested by FOX Petroli, the plant monitoring system was installed with 3 redundant Movicon supervision stations, connected to a S7-300 PLC in Ethernet. This kind of architecture guarantees complete control and security of all the Biodiesel's plant process procedures. This project, that ESEA developed, has been designed to monitor and supervise the whole plant which is divided into 9 process sectors corresponding to 9 reactors that produce Biodiesel using a reaction process starting with the main raw material, rapeseed oil.

In addition to supervising the production process, the system guarantees traceability (tracking) of each sector's process by recording data in a Ms SQL Server database system relating to the quantities of raw materials used (Rapeseed oil and alcohol) and the final product quantities attained (Biodiesel and Glycerol) generated from each of the reaction systems.

Moreover, this supervision system permits simplified production recipe management to enable workers to easily identify and manage all the process working parameters, a further plant management improvement.

Production recipe storage, automatic redundancy, are based on relational MS SQL Server Database.

The plant system had to be revamped in order to adapt to the increasing demand for biofuel and enable the management to increase productivity.

The system controls:

- 50 analog quantity measurements including flow meters, reactant measures, Level probes and temperature probes,
- 16 litre meters,
- 30 Digital Levels,
- 60 Motors and pumps, ,
- 45 Electrovalves,

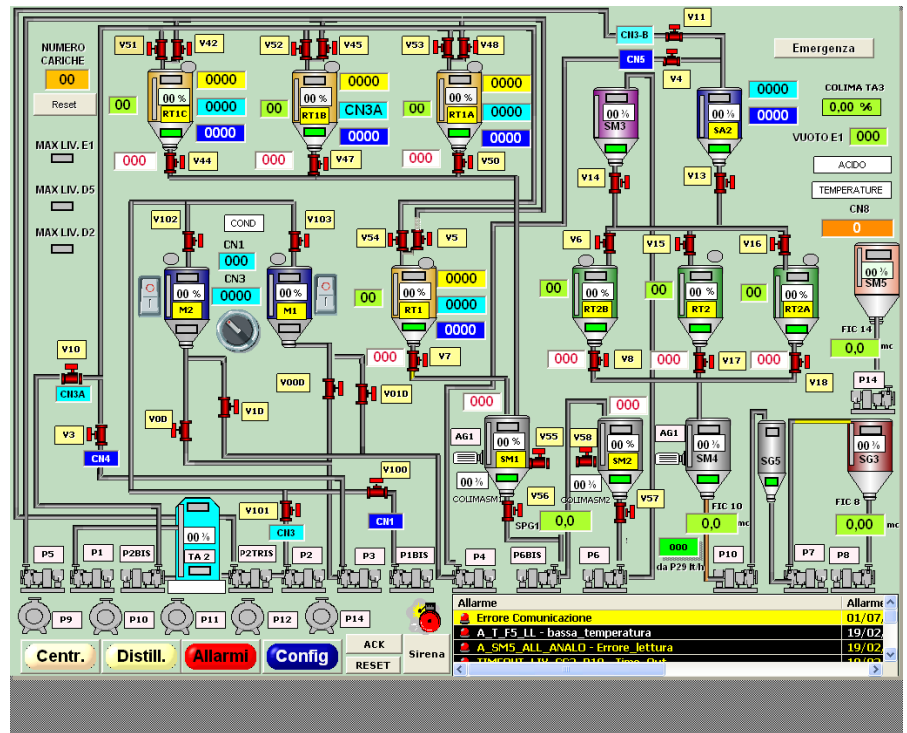

A screen page showing one of the plant's reaction systems.

### Productivity increment

The market has seen a significant rise in the demand for biodiesel in the last few years. In this context, the FOX Petroli offer has made it necessary to adopt effective, productive and performing solutions capable of guaranteeing maximum efficiency and productivity with management cost effectiveness. The strategic position of the FOX Petroli's plants also contributes to reaching these goals as apart of the raw materials are delivered directly by sea and the rapeseed is harvested close by. After the first raw material refining process, both the oils and alcohol are passed through a series of reaction processes ending up as Biodiesel and a by-product called glycerin. This glycerin is sent to storage to be used in other types of industrial sectors.

By using the Movicon Supervisor's purposely designed graphical screen pages, the operator can control and monitor all the operations and processes, starting from warehouse storage, refining and reactor processes and stockpiling of produced materials comfortably from the factory control room. Being an extremely complicated process, the operators are capable of supervising the whole system with maximum security and guaranteed continuity, thanks to the three redundant terminals.

Before the plant was revamped, factory floor workers had to start each reactor up manually, causing a series of problems which at that time could not be properly controlled and managed correctly by the company. This led to further inefficiency amounting from continuous and repetitious downtimes and production delays due to not being automated. Eventually things just simply got out of hand. To complicate matters even further, maintenance staff often worked overtime trying to fix breakdowns whose causes were difficult to pinpoint, inevitably prolonging the already long production downtimes. Today, thanks to the new adopted technology and Movicon, operators can easily run and manage the whole plant with easy guided screens clearly showing all the process phases.

Alarms or anomaly are alerted automatically and guide maintenance staff to restore production or provide information on targeted interventions or preventions based on historical analyses and statistics taken from data recorded on the most frequent or longest downtimes.

**Traceability and reports**

The company management wanted a sophisticated historical and analysis management, that could guarantee traceability not only of events but also all of the production processes and parameters recorded during production time. In order to satisfy these requirements, all analogical data is stored in appropriated relational database archives, based on MS SQL server, where recording takes place at preset 5 minute intervals according to specific needs and process times. Historically logged data is then displayed by the supervisor in Trend windows, fundamental feedback on how the plant performed so that different set-up parameters can be changed, if need be, to optimize product quality and plant efficiency.

Trends are used for viewing and analysing different time ranges of the plant production. Detailed curve lines represent production trends and can be printed according to defined or zoomed time ranges or for the whole production period in general. In addition to this, recorded data can be displayed in reports and on production and consumption tables. For example, operators can view or print the total amounts of Biodiesel produced or rapeseed and alcohol raw materials consumed by time range, batch or shift.

Eng. Di Prinzio  
Automazione Srl Gruppo ESEA.

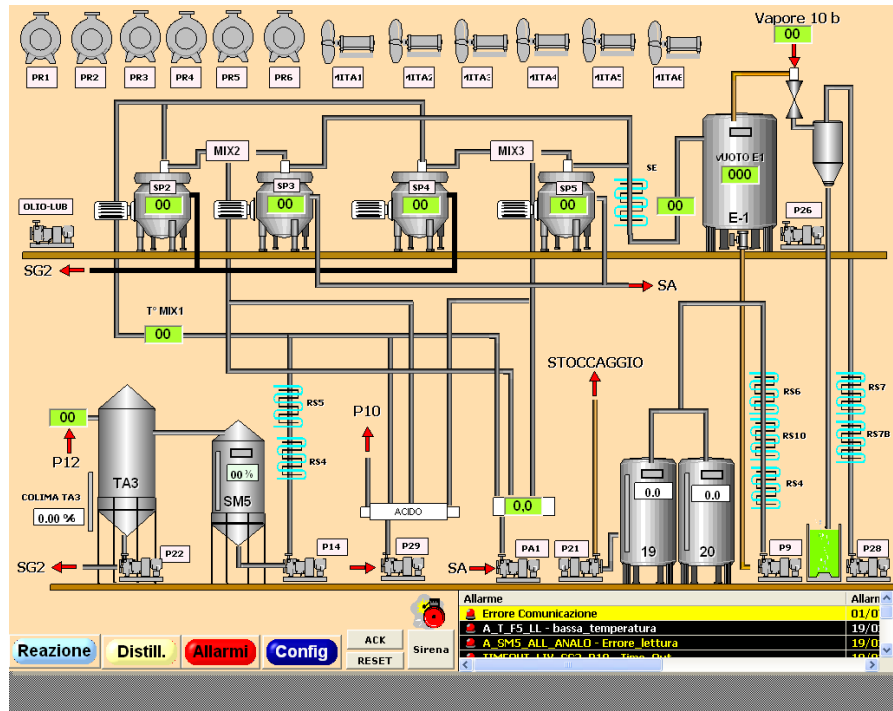

Screen showing the reactor zone where centrifugation is managed. Productivity is improved thanks to userfriendly supervision.

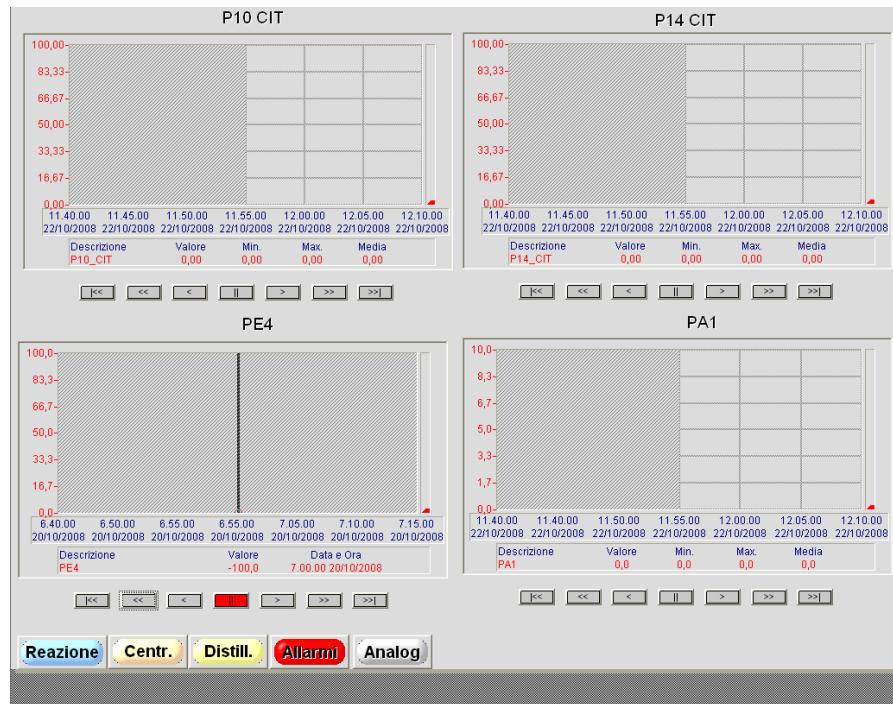

An example of a graphical display showing all analogical data in realtime and for historical analysis.