

Intelligent Skyscraper Control thanks to buses

Controllers with buses, designed by Picodata for building automation systems using Movicon for building supervision and control, are today used in Milan's Porta Garibaldi National Railway station's multistory office buildings.



The Milan Porta Garibaldi railway station skyscrapers controlled by the PICodata bus and the Movicon supervisor.

PICodata has been developing advanced technology for integrated **"building Automation"** systems for over twenty years.

With their consolidated know-how in designing and creating building automation systems, PICodata is capable of providing highly reliable solutions for complete system controller integration, system technology management, security, fire alarm and burglar systems, centralized and automated control. These systems consist of hardware components based on buses specifically designed by the company to guarantee the management of a vast range of functions correlated to building systems which can be widely distributed over horizontal and vertical levels and interconnected with other remote management control systems.

PICodata recently adopted the Movicon Scada platform, the well known supervisory system, found to be particularly open, powerful and simple to use, with indispensable Building Automation features.

This article is about the perfect integration between different hardware products, PICodata buses and Movicon, and their significance in the application created especially for the Infrastructure Division of the National State Railway Station during

2000, now the Rete Ferroviaria Italiana Spa (the Italian Railway network) and applied to Milan's Porta Garibaldi Central Station.

This tailor-made control system manages the skyscraper's technological systems of the two 24 storey tower blocks housing the national railway's management and administration offices.

The PICOdata consignment entailed designing, engineering and installing the system's hardware control devices and supervision software. The project aim was to control and monitor the buildings' technological appliances using modern technologies based on I/O architecture distributed by bus with local independent control and supervision based on an open and flexible Scada platform.

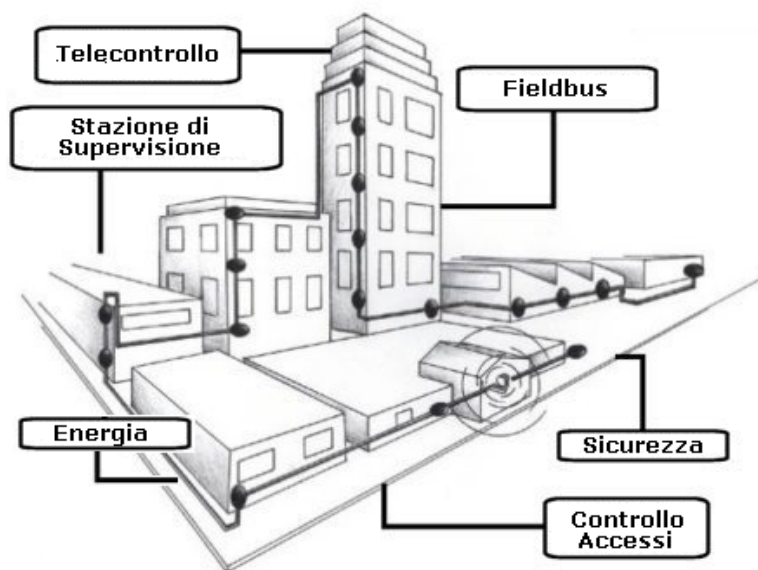

The system they designed controls the following systems:

- Public area lighting system
- Office lighting system
- Emergency light system
- Air conditioning and heating systems (fan coils)
- Public and service lifts
- Electrical cabinets

The adopted architecture clearly reflects the PICO data's determination to engineer an efficient and flexible system to implement and run at a low cost by:

- Using a simplified communication method which increases system reliability and data transmission velocity.
- Simplifying cabling operations as much as possible to both reduce intervention costs and make them easier to carry out in buildings already completed construction.
- Implementing a supervisory software that can be used by non expert personnel to control the whole system

THE SYSTEM IN GENERAL

Supervision is carried out through a system structured on three different levels:

- Physical field device level dedicated to gathering data on devices and /or controlled systems or generating commands to go into effect automatically.
- Transmission level involving data transmission and reception protocols to and from the field.
- The control level where application interacts with the above mentioned levels in order to generate the desired process and control logic.



I/O modules distributed on buses made by PICOdata

The physical level is composed of remote I/O devices purposely designed and produced by PICOdata for simplifying and making generic electric wiring and cable connections, up to a distance of 8km, more cost effective. The BOSS-4 devices used have 4 opto-isolated inputs for monitoring, 4 outputs in micronetwork for controlling and a built-in Motorola 68HC11 to slim down communications with the central supervisory unit.

The supervisory and control software was developed using Progea's Movicon SCADA environment. This made it possible to design a very effective software application with an immediate and easy-to-use user interface and an efficient redundancy system for central monitoring process unit back up to guarantee system continuity at all times.

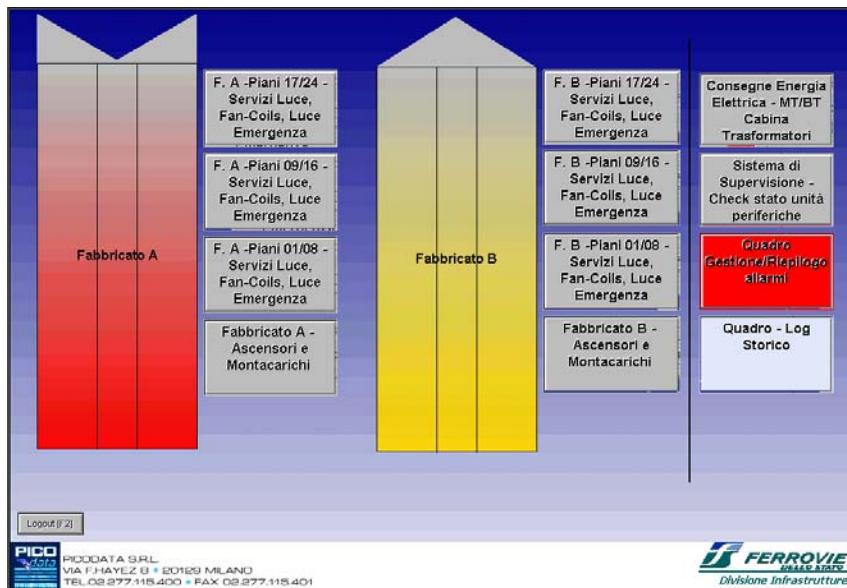

The National Railway office building system's main screen

The software operates through screen pages, permitting the user to monitor the entire building by being able to display and view the status of the whole system, each peripheral unit and view and acquire data on alarms or messages generated by the system and its components. In addition, the user can manage the turning off/on of the various systems, such as lights, fan coils, public and service lifts, and monitor their statuses.

Thanks to the supervision software's simple and intuitive user interface, the operator can use manual/automatic command selections to exclude those parts of the system undergoing maintenance and access historical event files with a few simple clicks.

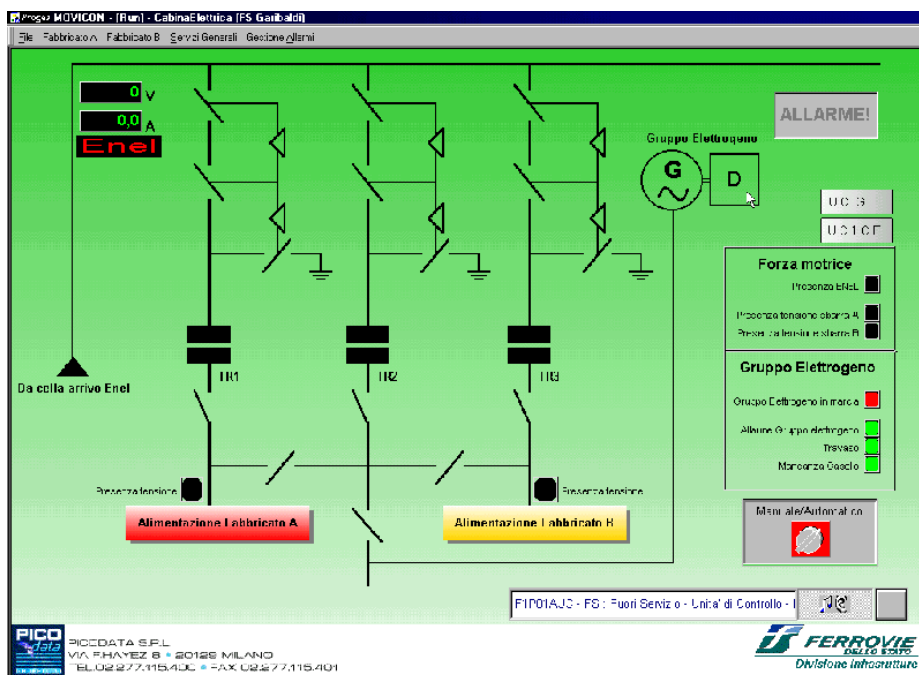

One of the system's screens designed by PICOdata with Movicon.

The solution projected by PICOdata has fully satisfied their client's needs, guaranteeing information distribution throughout the building thanks to the bus system and system control guaranteed by the Movicon supervisory terminal. Security is completely guaranteed by the supervision's hot backup redundancy system.

System openness allows the client to add or enable new and ready-to-use functionalities in the future, which include managements such as vocal calls and remote control of connected devices both through the web or Wap wireless technology. In particular, the solution proposed by PICOdata is easily implemented and fully equipped to satisfy any building control need especially for those clients wishing to unite deployed system openness to necessary performances for enhanced modern system management.