

Lonworks and Movicon technology book into the Grand Hotel.

An Apice Srl solution proves you can get the maximum advantages out of uniting bus technologies and Scada systems in a Building Automation matrimony.

Over recent years, building and room automation has witnessed many proposals in the ever increasing performances of new control network functions and features. Cutting Edge technology has also been applied to the world of Building Automation offering astounding advantages for both installers and end users. One automation system of this kind has been created by Apice Srl on request by the Grand Hotel Elba International **** general management. This four star hotel is situated in the enchanting bay of Capoliveri on the Island of Elba and its owner is a great believer in harmless and environmental



friendly technology, water recycling and is a great nature lover.

The Elba International complex is a luxury 150 room structure based on cutting edge eco-architectural technology, surrounded by a flourishing 20-acre natural woodland park on the sea front.

The whole complex has been designed to be energy efficient with internal microclimate control systems, renewable energy, water recycling in lawn irrigation, and waste reduction by separating it for recycling according to type including organic compost disposal. In order to accomplish the hotel directorship realized the most modern technologies were needed and unanimously decided to revert to a top professional company dealing in this field. This very company happened to be Apice Srl, a Tuscany company which develops, produces and provides support for the Building Automation sector.

After taking into consideration the various demands and needs of the hotel, Apice chose the LONWORKS® technology and the Movicon scada platform, thought the best for developing the particular applications required and which allowed integration of other different products. Quick to respond with cutting edge technology solutions for building automation integration using this type of philosophy, Apice has earned its rightful place in the continuous and fast growing market. Equipped with its own powerful techniques and technical know-how gained throughout the years in this sector, APICE has established itself as one of the most qualified companies in Italy specialized in planning and developing Building Automation access control and security systems. The Hotel Elba International **** system was also developed with the collaboration of the Impianti Elettrici Tagliaferro company from Porto Azzurro

*The splendid view enjoyed from the Hotel Elba International ****, a huge complex managed by the Apice systems designed using LonWorks and the Movicon Scada software.*

The System

A robust and efficient network infrastructure is a crucial factor for the correct running of building automation systems. It must also be designed with the intention to expand and therefore big enough to cope and accept future proposals. With this in mind, Apice built this system to sustain over 350 LonWorks nodes and routers. The main objective was to create and obtain room comfort, energy efficiency, the necessary automation for the various technical devices, protection circuit breaker supervision, technological system anomaly detection and remedy and lighting management. These objectives were accomplished by using the minimum of hardware products possible, in fact only 7 different product nodes were installed:

- Thermostat node (150)
- Room fancoil and power command node (150)
- 6 input and 4 output nodes (60)
- Central Heating temperature node (1)
- External light sensor node (1)
- Room access manager node - LonServer - (1)
- Key transponder reader manager node (2)

The number in brackets indicates the quantity of nodes installed. As anticipated, there is no need to stock many spare parts. Two types of applications have been installed for modules containing 6 inputs and 4 outputs according to local functional purposes. One application is directed towards controlling lights, the other oriented at controlling power supply.

The following architecture was used to enable this:

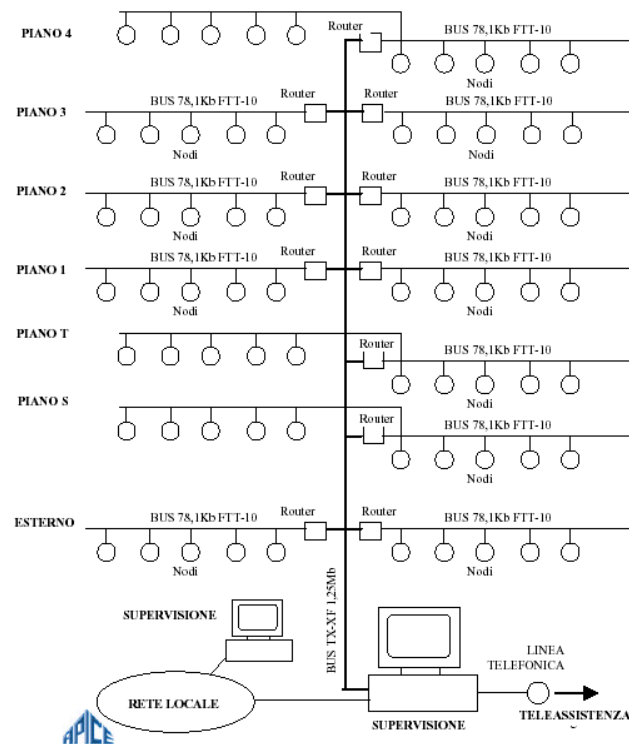

As you can see from this diagram, the 1.25 Mb TP-XF transmission standard has been used as a vertical backbone for quick efficient connections and message forwarding.

One or two routers have been used on each floor with parallel tasks to transform the TX-XF 1250 standard to FTT-10, working with 78Kb, and to isolate network traffic.

The FTT-10 standard is widely adopted for connecting nodes with LonWorks, easy accessible

technology available on today's market as "free technology". The reason being that this technology permits nodes to also connect without being wired directly to a Bus system (being each device connected to the main branch one after the other) but in a daisy chain nature by connecting to another node stemming off from the node directly branched off the bus.

Network traffic isolation works in such a way that all messages are exchanged between nodes through a router without being propagated throughout the rest of the network occupying bands unnecessarily.

The advantages of using this standard is that in an event of a network breakdown, such as the bus short circuiting, only the sub-networks are affected and not the whole system making it easier to detect the exact breakdown location. The Movicon supervisory has been installed on a PC with Windows NT operating system and a Lonworks network interface card with TP-XF 1250 output, installed directly on the PCI bus. By using the Progea Scada system it took much less time to develop projects thanks to its user friendly and powerful inbuilt features guaranteeing openness for future integration of other devices. Movicon is a worldwide distributed and installed product which comes with technical assistance services provided especially to users at the teething stage.

Thanks to the node intelligence all the automation deemed indispensable can be created for all technological and lighting systems without needing specific application development or central supervisor usage. Just by connecting one module's variables to another's and configuring the software appropriately has proved the Movicon applications to be extremely versatile.

The absence of a central supervisor to coordinate the activity of the various I/O modules means significant system reliability in as such that there isn't just one component that determines how everything works, being a distributed intelligence and therefore any node breakdown will only cause a brief service downtime of that node, without interrupting the normal running of the rest of the system.

All the applications used are LonMark standard ready which guarantees complete system openness to further expansion in the future.

Reading LonWork field values

Field values are basically read using two different mechanisms: Some values are connected directly to the PC. This means that when the node in the field records a status change it automatically informs the supervisory PC, without being requested to. For instance, protection circuit breaker alarms are connected directly to the PC, when a circuit breaker is switched OFF (or ON) this change is relayed directly to the PC. The great advantage is that value change notifications are instant and network traffic is lightened by the fact there are no continuous value change requests by the PC. As notification is instantaneous a technique is used for sending them spontaneously at regular intervals, i.e. every minute or 30 seconds to avoid losing any if the PC should get turned off or disconnected.

Management and Supervision:

Movicon as a supervision system, permits communication with the Echelon bus and read or write of all devices, displaying all statuses on video screen pages, acquiring alarms, controlling and monitoring devices wherever needed and recording control parameters on file. This control station is located at the hotel reception desk.

Among the supervisory features you will find information on room status, lighting management, electric power mains and protection circuit breakers, pump and central heating control, extractor fans and other technological devices used. Particular attention has been paid to the diagnostics and historical event logging, to enable management and maintenance improvements of the whole hotel complex.

This system refers to a hotel whose main supervision is focused on the 150 rooms. A main screen page reports all information on the status of these rooms. This kind of visualization has been created by simulating a rack where the keys are hung. Different types of icons have been placed on screen to show the various statuses of each room:

Occupied cleaned Guest is in the room which has been cleaned.

Occupied not cleaned Guest is in the room which still needs cleaning

Free cleaned Guest is not in the room which has been cleaned

Free not cleaned Guest is not in the room which has not been cleaned.

Vacant Room has not been assigned to any guests.

Room Cleaner Room is being cleaned.

Alarm The bathroom alarm has been sounded.

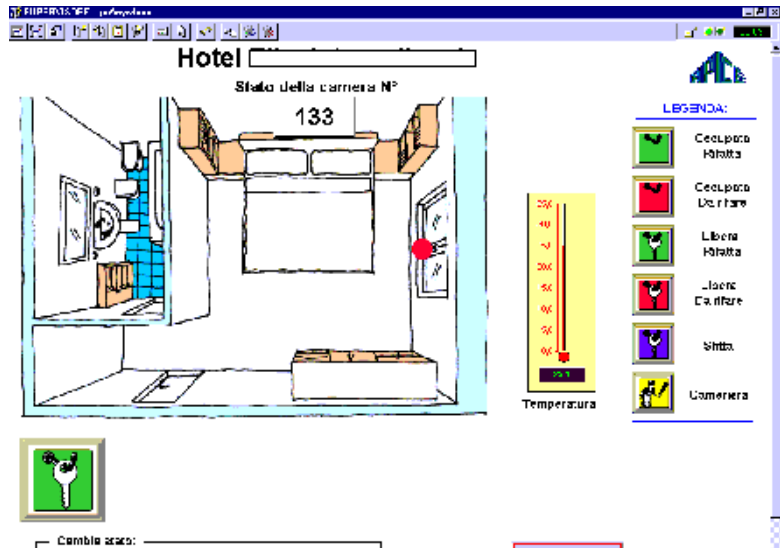

A screen displaying a detailed hotel room situation in realtime.

Being so userfriendly it does need any specific learning and can be managed easily by any authorized personnel.

Room management has been designed to guarantee maximum comfort on an energy efficiency and environment safety ratio. When the room is "occupied", the heating and electrical systems are automatically activated. The guest can then regulate room temperature to their liking. When unoccupied, thus "free", everything except the fridge is deactivated. The heating system, whether customized as pleased by the guest or not, is switched on to automatic at a previously programmed set-point for summer and for winter. If the room is left "vacant", this set-point is slightly reduced for both summer and winter seasons to save energy even further. The "Room Alarm" condition has top priority. This icon will blink alerting hotel staff that guest has pulled the bathroom emergency cord and needs assistance straightaway. By double-clicking the icon, the alarm window will open allowing staff to return room status back to normal. All alarms are recorded and stored in a historical log as described below.

These screens also show the status of all the room windows. When a room window registers "open", the fan-coil ventilator is automatically disabled.

Personnel can access all detailed information of each room by double clicking on the relative screen page. Window status and room status can both be accessed through the same main screen icon while bathroom alarm and room temperatures are all displayed for clear viewing. Room statuses can also be forced manually whenever necessary.

Floor Situations:

The electric cabinet on each floor can be controlled by using the other supervisory pages. In this case we have:

- Electric cabinet door open alert.
- Protection circuit breakers.
- Management of two light circuits.
- Fire damper.

Whenever an electric cabinet door is opened, as in this case, the supervisor is alerted and a silent alarm is generated for recording the event. This process was opted for so that non serious alarm events could be recorded and made ready for viewing before alerting personnel.

When a protection circuit breaker goes into action an alarm is sounded and the circuit breaker is displayed in the OFF position with a blinking lever to capture the attention of the personnel responsible. Whatever page is being viewed at that moment will automatically be substituted with the one containing the device whose alarm has been sounded. This choice of process is determined by the importance of the event: if a general floor circuit breaker is triggered, a whole hotel wing will remain without electricity and will need seeing to immediately.

Each hotel wing has two light circuits; one circuit has been dedicated to night time, and the other to midnight hours

Each circuit had been adapted with a selector switch which can be activated with a mouse click. These switches can be positioned to automatic, manual OFF or manual ON. When positioned to manual, the light circuit is always ON or always OFF and when positioned to automatic the following apply:

“All night” the lights turn on when external day light reaches a certain threshold during a 24 hour span, “Midnight” the lights only turn on when external day light reaches settable time range thresholds. The circuits are turned off when not within time range.

There is a push-button panel situated at Reception so that all the midnight light circuits can be controlled on a temporary manual basis to force lights on or off if required. When supervisory is set with automatic light circuit mode, these operations will automatically be cancelled when time range expires and restored to automatic mode again.

When the light circuit is actually on, the light bulb symbol will show. This would be for the night time circuit in this case. The turn lights on set -point can be configured individually for each circuit.

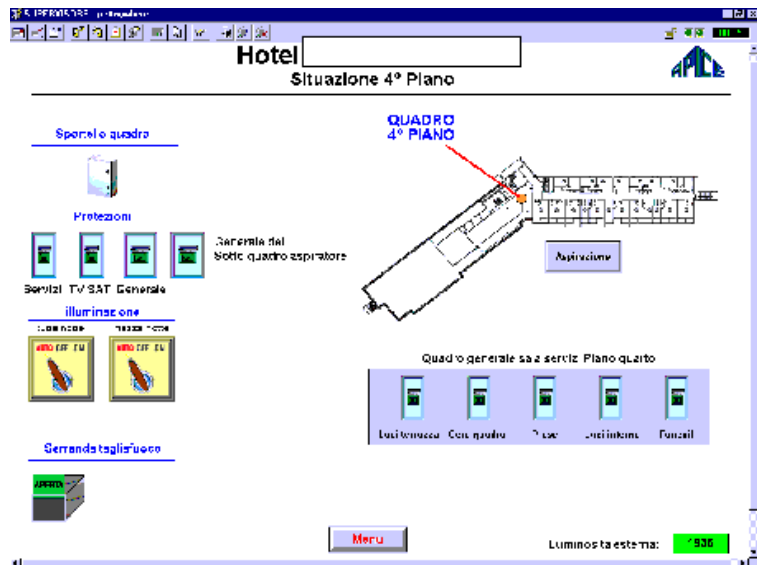

Movicon screen displaying the whole hotel complex clearly showing each operating status of all devices distributed across the LonWorks network.

Technological Managements:

Hot and cold water is managed with 6 heat pump compressors. The optimized power consumption management permits pump activation when only effectively needed in order to rationalize system resources. These heating pumps can be turned on/off either by the supervisor, at the local heating supply point or from the actual heating pumps. The Movicon system manages a particular logic type for turning pumps on/off at any location where this procedure can be done. Any pump anomaly is acquired by the system and alerted with alarms.

A screen page has been entirely dedicated to the all the technological pump services where all the devices involved are displayed and managed. This is very handy for maintenance staff who can also access this page by remote control from the actual maintenance work location to get on-the-spot optimized and improved diagnosis of the repairs needed.

Another page has been dedicated to managing external illumination while yet another is used for managing lights within the ground floor hall and its public areas. Each single light status can be viewed and controlled manually using a graphical map layout.

These light circuits are managed parallel to the floor management and can be rationalized automatically or manually. As each circuit has its own independent set-point, the hotel managers have chosen to turn them on gradually as night falls to create just the right choreographic light scenario without consuming too much energy. A screen page has also been provided for bathroom air ventilators positioned on the hotel rooftops. All circuits are well and truly controlled and monitored.

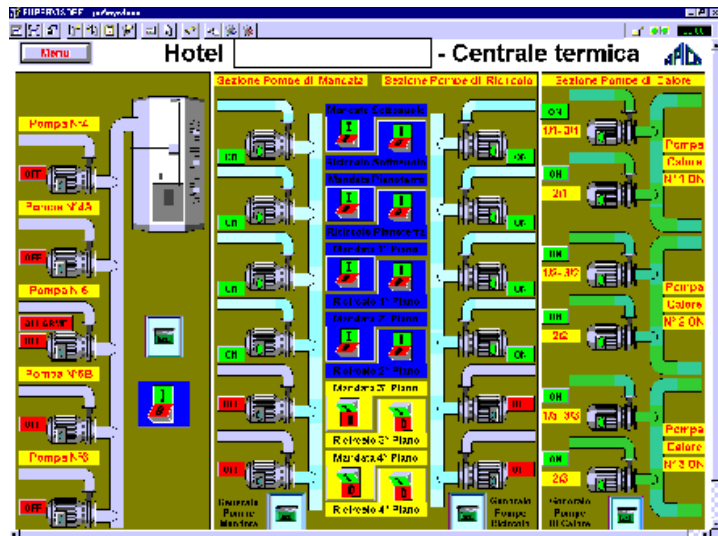

The technological and central heating services are kept under complete control by the supervisor for easier management and maintenance aided with remote control.

Alarm Screen:

When an alarm occurs, a graphical screen page will immediately appear showing the device concerned and the supervisory PC will sound the alarm acoustically. By double-clicking on the device in alarm, or explicitly calling the relative page, a window will show containing alarm occurrence causes together with the possible remedies or operations needed to fix them.

The alarm must first be acknowledged to silence it. Both the alarm acknowledgement and occurrence times are automatically recorded in the historical log. Once acknowledged the alarm will remain visible in the main window until the problem in question has been put right. Any attempts to reset it beforehand will cause it to reappear in the window.

For instance, if a protection circuit breaker alarm occurs, someone will physically have to go to the relating cabinet and fix it. Once this has been done, the alarm can then be reset automatically recording the whole event in the historical log.

Staying at the avant-garde Grand Hotel Elba International has never been so enjoyable and comfortable. Great benefits gained by using the Lonworks technology together with the Movicon Scada platform to improve and optimize hotel management and maintenance.

Raul Stefanelli
Apice Srl