

Solutions to all the field of PET



A part of the Shanghai Zi Jiang Group's PET bottle production plant in China.

CSA Laboratories, a part of the Piovan business group, develop control systems in the plastic industry sector, and has recently realized a bottle production plant in PET based on Movicon for the Shanghai Zi Jiang, Chinese business group

Piovan is one of the international leaders in planning, producing and installing systems aimed at special problems. Their long experience in the plastic material sector, and collaboration with raw material manufacturers and transformer machines, is based on the company's capacity to propose not only standard solutions but also avant-garde plant engineering solutions.

CSA Laboratories, a business group which projects and realizes supervision software, have recently devoted themselves to control systems in industrial plant management, by specializing in producing software dedicated to apparatus control in plastic material manufacturing plants. In just a few years this company has projected about 50 supervision and control systems installed all over the world.

The plants realized by the group in the leading International industries of PET

transformation, now offer high-quality and highly reliable products. Increased transparency and low level acetaldehyde in moulding, perfect surfaces without any mould imperfections, higher elasticity and mechanical resistance in special spinning processes are just some of the main characteristics which the Piovan machineries can guarantee in the PET transformation process. Reliable machinery is the result of the choice of inoxidizable materials used in air humidifier generators, first choice quality components and insulation of parts generating high temperatures. The matured experience gained in feeders up to 1000 litres has been transferred to high capacity feeders up to 10,000 litres, guaranteeing uniform material, the maximum exploitation of processed air, and a reduced heat loss, thanks to much thicker insulation.

Solutions have been provided for both feedboxes on transformer machines and stand alone feedboxes. The process systems have been conceived to guarantee maximum integration, including crystallizers, masterbatch dosing or liquid colouring, mould ambient dryers, mould coolers and press, as well as PC supervision of all the other apparatus involved.

This guarantees the Client the advantage of having a unique source of knowledge and services.

CSA is an independent company in the group, born for developing software by disposing its advanced technological know how techniques on the market. The world of injection, extrusion, plastic material blowing therefore represents the core business of the company even though experiences in diary farming and aviculture are being carried out with particularly created applications. This company had therefore decided to use a Scada platform as a base software for its applications. After having examined all the consolidated products on the market, the choice fell on Movicon, an open and scalable product with best quality, best price relationship.

CSA Laboratories have been using Movicon with great satisfaction for over two years, and a practical example as a consequence of the advantages of its usage have been demonstrated by the company's recent debut to a particular and demanding market, such as that of the Chinese, by projecting a PET bottle production plant control software for the Shanghai Zi Jiang company Group, based in Shanghai, China. The plant has to meet the demands of a vast area of China and which is itself very remarkable: it is built of 20 PET islands which feed injection press for producing moulds. The system controls the flux and treatment of plastic material from storage to entering the press. Storage is either done by pressure loading from lorry tanks or from containers into 4 silos. The supervision system controls and manages the entire process, guaranteeing the correct feeding into silos to avoid any material pollution that might cause disastrous effects on the final production, as well as detecting and signaling any malfunctions.

The threshold selections and the material destinations are carried out through an intuitive system, using the appropriate predefined purpose windows where the operator is guided from the beginning to the end.

The system also provides the use of reading

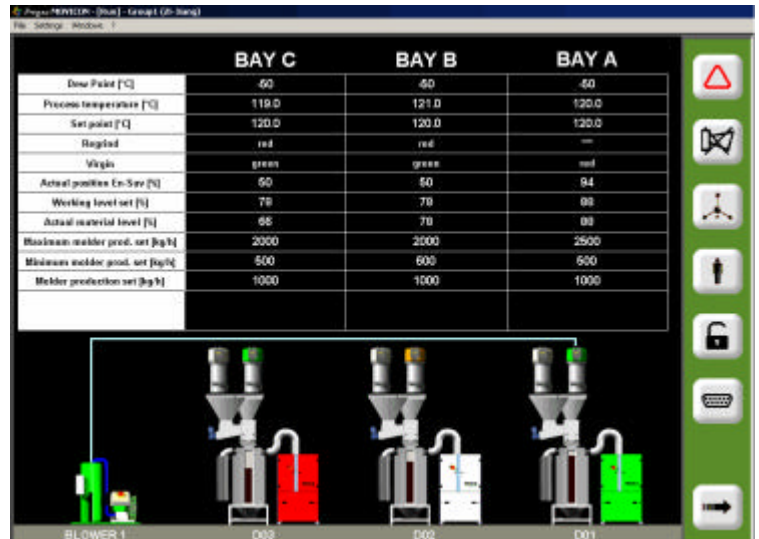

Plant supervision is based on Movicon, thanks to which the different PC stations guarantee the reliable and secure control and data acquisition.

bar codes, managed by the Movicon supervisor, through which the materials arriving from the warehouse are recognized and automatically sorted out without any errors being caused.

Materials coming from the silos are conveyed to dryers by means of a vacuum operated transport system which uses entirely controlled devices and shunting conveyors.

It is highly necessary that absolute security is guaranteed at this particularly critical stage where the material must be shunted and sent to the correct mixer and dryer islands. This management is controlled and guaranteed by the plant through a decoder system qualified to certify the correct feeding of material to the islands.

Finally the whole mixing, drying process and energy saving is controlled with the most extreme security and effectiveness, guaranteeing the exact dosage and perfect material drying and mixtures set on recipes by the user and managed by the supervisor.

The end result clearly presents the utmost assured and highest quality, while optimizing the consumption of energy resources at the same time.

Client requirements are concentrated into total process control in terms of setting, reading and archiving, based on user-friendly and intuitive touch screen graphical interfacing. Particular care has been devoted to these last aspects, which are often found to determine plant conditions for its operators. The graphical diagrammed pages are particularly pleasant to look at thanks to the powerful Scada platform being used.

The system management, information distribution and archiving of mixture recipes is done on two PC stations based on Windows 2000 and are linked together in TCP-IP Ethernet network.

The alarms management permit warnings and critical situations to be clearly indicated, by chronologically recording all the events. The historical archives, based on industrial and open DBs, permits the realization of all the settings to be carried out by the operators and the alarms taking part.



Great care has been taken in the designing of the system synoptics to guarantee simple and intuitive plant conditions for the operators.



The plant realized at Shangai covers the bottle production in PET for one of most largest areas in China.

The plant's relative data of material being worked on and all the processes significant analogic is recorded on appropriated ODBC related databases, allowing detailed reports and statistical reports to be produced and at the same time guaranteeing an open and independent system. In addition to all this the client is guaranteed any future plant integration with information business systems.

In particular the MovSPC (Statistical Process Control), a Movicon graphical analysis module, which has been employed to carry out statistical analysis on the statuses of large processes.

Thanks to this SPC supervisor module any optimal parameter variations can be statistically traced, by means of viewing graphics (Gauss, Deviasion Standard, X-Bar, etc.), which can then be used to make way for immediate production improvements to certify good quality.

The supervision system also manages protected plant access, by means of a sophisticated and complete password management and user profiles with relative access levels based on the user's rank.

The Movicon Scada platform has demonstrated to CSA Laboratories to be the most suitable tool for all their specific requirements permitting highly reliable and solid applications to be developed in the shortest of time with a pleasant interface that captures the operators immediate

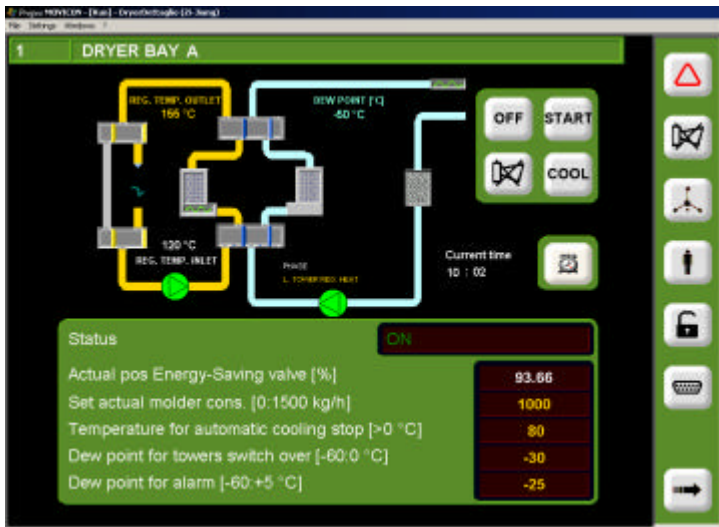

The supervisor acquires data, alarms, manages recipes, historically logs production data to produce SPC reports and graphs.

intuitivity and enjoyment (Client training only takes 3 days).

The reasons for choosing this product are due to its large scaling ability, great simplicity and openness to guarantee the possibility of implementing above the normal standard management.

Progea has demonstrated how precious and immediate its assistance is during the application planning stage and its collaboration in the development of communication drivers with custom hardware devices used in the plant.

The target of automatizing the production process and to reduce down time machines has been completely reached, keeping costs well within the pre-estimated budget limits and thus prompting the client's concluding declaration of complete satisfaction.

Thanks to:

Ing. Valerio Zampieri
CSA Laboratories srl